



Study of the involvement of the RGR, CRPB1, and CRB1 genes in the pathogenesis of autosomal recessive retinitis pigmentosa

S Bernal, M Calaf, M Garcia-Hoyos, B Garcia-Sandoval, J Rosell, A Adan, C Ayuso and M Baiget

J. Med. Genet. 2003;40:89-
doi:10.1136/jmg.40.7.e89

Updated information and services can be found at:
<http://jmg.bmjournals.com/cgi/content/full/40/7/e89>

These include:

References

This article cites 23 articles, 7 of which can be accessed free at:
<http://jmg.bmjournals.com/cgi/content/full/40/7/e89#BIBL>

Rapid responses

You can respond to this article at:
<http://jmg.bmjournals.com/cgi/eletter-submit/40/7/e89>

Email alerting service

Receive free email alerts when new articles cite this article - sign up in the box at the top right corner of the article

Topic collections

Articles on similar topics can be found in the following collections

[Online mutation reports](#) (134 articles)
[Genetics](#) (3374 articles)

Notes

To order reprints of this article go to:
<http://www.bmjournals.com/cgi/reprintform>

To subscribe to *Journal of Medical Genetics* go to:
<http://www.bmjournals.com/subscriptions/>

ONLINE MUTATION REPORT

Study of the involvement of the *RGR*, *CRBP1*, and *CRB1* genes in the pathogenesis of autosomal recessive retinitis pigmentosa

S Bernal, M Calaf, M Garcia-Hoyos, B Garcia-Sandoval, J Rosell, A Adan, C Ayuso, M Baiget

J Med Genet 2003;40:e89(<http://www.jmedgenet.com/cgi/content/full/40/7/e89>)

Retinitis pigmentosa (RP), which occurs in about 1 in 3000-7000 people in Spain, is inherited in an autosomal dominant manner in 12% of cases, in an autosomal recessive way in 39%, and in an X linked manner in 4% of cases.¹ This leaves 41% of RP cases with a simplex form and 4% in which the transmission pattern is unclear.

The different genes that have been implicated in retinal degeneration are known or assumed to be expressed in the photoreceptor cells of the retina or in the retinal pigment epithelium (RPE). The large number of RP genes identified can be grouped into a number of functional classes: (1) proteins of the visual cascade, (2) proteins of the visual cycle, (3) photoreceptor cell transcription factors, (4) proteins related to catabolic processes, and (5) genes of unknown function.

Previous studies performed in autosomal recessive retinitis pigmentosa (ARRP) Spanish families have shown that genes coding for recoverin,² rhodopsin, rod outer segment membrane protein and peripherin/RDS,³ S antigen and the gamma subunit of rod cGMP-phosphodiesterase,⁴ interstitial retinol binding protein,⁵ the alpha subunit of rod cGMP-phosphodiesterase and NRL,⁶ and the retinaldehyde binding protein⁷ do not play a role in this disorder. However, mutations in the beta subunit of the rod cGMP-phosphodiesterase gene,⁸⁻¹¹ in the ATP binding cassette receptor gene,¹² in the *TULP1* gene,¹³ in the alpha subunit of the rod cGMP gated channel,¹⁴ and in the *USH2A* gene¹⁵ have been detected in a small percentage of Spanish ARRP families. These data indicate that other genes play a part in the degeneration process of the retina in the remaining families.

We analysed the involvement of three additional genes, the RPE retinal G protein coupled receptor (*RGR*), the cellular retinol binding protein (*CRBP1*), and the crumbs homologue 1 (*CRB1*) (table 1) in 92 ARRP Spanish families.

RGR is an integral membrane protein that is expressed in the cytoplasm of RPE and Müller cells.¹⁶ It is a member of a large family of G protein coupled receptors and shows considerable overall homology to the visual pigments and retinochromes. Under light conditions, *RGR* converts all-*trans*-retinal to 11-*cis*-retinal, whereas the reverse isomerisation occurs within rhodopsin.

CRBP1 belongs to a family of cytosolic proteins whose members bind various hydrophobic ligands. This protein is a component in the retinal pigment epithelium where it is believed to function in intracellular storage and transport of retinol.

The *CRB1* gene is expressed in human retina and brain. It exhibits alternative splicing at its 3' end and the four classes of mRNA are predicted to encode four different proteins, two of which are found in human retina.¹⁷ Given its homology to the *Drosophila* Crumbs protein that is required for polarity and adhesion in embryonic epithelia, it has been postulated that the role of *CRB1* in vertebrate photoreceptors may be in cell adhesion and photoreceptor morphogenesis. A role in localis-

ing the phototransduction complex to the apical membrane of the photoreceptors has been proposed owing to the specific expression of *CRB1*.

MATERIALS AND METHODS

Families

This study comprises 92 ARRP families including four families with retinitis punctata albescens (50 consanguineous and 42 non-consanguineous pedigrees). Most of the families were examined ophthalmologically at the Hospital de la Santa Creu i Sant Pau in Barcelona or at the Fundación Jiménez Díaz in Madrid. The clinical diagnosis of RP was based on ophthalmological examination including measurements of visual acuity, ophthalmoscopy, dark adaptation, ocular tension by air tonometer, perimetry, and electroretinogram amplitudes according to ISCEV protocols.¹⁸

METHODS

Blood samples were obtained after informed consent was given and genomic DNA was extracted from leucocytes of peripheral blood from each patient.¹⁹ We used single strand conformation analysis (SSCP) to screen all exonic sequences (including intron-exon boundaries) containing the open reading frame of the *RGR*, *CRBP1*, and *CRB1* genes. Primers

Key points

- Autosomal recessive retinitis pigmentosa (ARRP) is a genetically heterogeneous form of retinal degeneration. The genes for the RPE retinal G protein coupled receptor (*RGR*) and the crumbs homologue 1 (*CRB1*) have been reported to be the cause of ARRP. Although no mutations in the cellular retinol binding protein gene (*CRBP1*) have been reported, we have considered this gene as a candidate for ARRP.
- SSCP analysis and DNA sequencing of the entire coding regions of these genes were performed in 92 ARRP Spanish patients. Several exonic and intronic single nucleotide polymorphisms were detected in the *RGR* and *CRBP1* genes. However, no disease causing mutations were found, suggesting that these genes are most probably not involved in the disease in this set of ARRP Spanish pedigrees. In contrast, the mutational analysis of the *CRB1* gene allowed the identification of a number of rare sequence variants and intronic polymorphisms and of seven pathogenic mutations.
- The ocular phenotype of RP patients harbouring these mutations confirms that considerable clinical heterogeneity is associated with mutations in the *CRB1* gene.

Table 1 Characteristics of the three genes included in the study

Gene name	Symbol	OMIM ID	No exons	Chr location	Size (kb)	Mutations report (references)
RPE retinal G protein coupled receptor	<i>RGR</i>	600342	7	10q23	14.8	22
Cellular retinol binding protein 1	<i>CRBP1</i>	180260	4	3q21-q22	21	-
Crumbs homologue 1	<i>CRB1</i>	604210	12	1q31-q32.1	>40	20, 21, 25, 26

Table 2 Results of mutation analysis at the genomic DNA level of the *RGR* and *CRBP1* genes

Gene	Sequence variation	AA change	Minor allele Frequency (%)
RGR	nt 19 C>T*	Leu7Leu	8
	nt 27 C>T*	Thr9Thr	49
	nt 459 C>T*	Tyr153Tyr	38
	nt 722 C>T*	Ser241Phe	2.6
	IVS6+5 A>G*	-	0
	nt 615 G>A	Lys205Lys	-
CRBP1	5'UTR-134 C>T	-	10
	5'UTR-37 C>T	-	6

*Reported in reference 22

corresponding to the complete coding sequence of the *RGR* and the *CRBP1* genes were designed according to GenBank entries NT_033890 and NT_005832 to yield PCR products in the range 200-350 bp. The 28 primer sets described by Hollander *et al*^{20, 21} were used to amplify the complete coding region including two promoter regions of the *CRB1* gene. PCR amplification was performed in a final volume of 25 µl containing MgCl₂ (1-2 mmol/l depending on the fragment amplified), 200 µmol/l of each dNTPs, 0.2 µmol/l of each primer, 0.5 units of *Taq* DNA polymerase (Ecogen) in the recommended buffer, and 100 ng of genomic DNA. The thermocycling conditions were 94°C for six minutes, followed by 30 cycles at 94°C for 30 seconds, from 53-63°C depending on the fragment for 30 seconds, and 72°C for two minutes, followed by a 10 minute final extension step at 72°C.

After amplification, mutation analysis was carried out using SSCP under two different conditions combining acrylamide concentration, running temperatures, and voltage. Fragments that showed abnormal patterns of migration by SSCP were analysed on an automated sequencer (ABI Prism 310, Applied Biosystems).

On detection of a sole mutant allele, the patient sample was subjected to direct sequence analysis of the remaining exons and of the promoter regions of the corresponding gene.

RESULTS

All deleterious mutations and genetic variants were assigned a nucleotide number starting at the first translated base of the *RGR* and *CRBP1* genes according to the GenBank entries U14910 and NM_002899, respectively. The corresponding accession numbers for the *CRB1* gene were AY043324 or AY043325 for isoforms I or II, respectively. Deletions were names in accordance with the HUGO recommendations.

RPE retinal G protein coupled receptor (*RGR*)

A PCR-SSCP strategy was used to screen each of the seven exons of the *RGR* gene in the 92 unrelated patients under study. SSCP band shifts were detected in DNA encompassing exons 1, 4, and 6. Sequencing of these fragments allowed the identification of six single base pair substitutions (table 2). Four of these single nucleotide changes were C>T transitions, three of which corresponded to previously described frequent polymorphisms.²² The remaining C>T substitution causing the missense change Ser241Phe was present in nine unrelated ARRP patients (eight carriers and one homozygote). Family studies in these nine ARRP families indicated that all the affected RP patients were carriers of the Ser241Phe in the four

Table 3 Results of mutation analysis at the genomic DNA level of the *CRB1* gene

Mutations	Sequence variation	Cd	Exon	Effect	Cosegregation
M-717*	nt 478^81 ins G	160-161	2	168 Stop	+
M-489*	nt 614 T>C	205	2	Ile205Thr (nc)	+
M-641*	nt 2244^47 del 3bp	749	7	delSer	+
B-102*	nt 2671 T>G	891	7	Cys891Gly	+
M-69/M-641	nt 2843 G>A	948	9	Cys948Tyr	+
B-15*	nt 2882^88 del 3bp	962	9	delLeu	+
B-102/M-69*	nt 3299 T>C	1100	9	Ile1100Thr (nc)	+
Rare sequence variants					
M-43	nt 867 C>T	289	4	Thr289Met (nc)	-
V-4/M-489	nt 1410 G>A	470	4	Leu470Leu (scc)	-
B-141	nt 1647 T>C	549	6	Asn549Asn (scc)	-
M-180*	nt 2035 C>G	679	6	Gln679Glu (nc)	-
B-50	nt 2306 G>A	769	7	Arg769His (c)	-
M-68	nt 3171 C>T	1057	9	Asn1057Asn (scc)	-
M-40	nt 3992 G>A	1331	11	Arg1331His (c)	-
M-69	5'UTR-268 G>A				
Polymorphic intronic variants					
	T/A		IVS1-12		-
	T/A*		IVS2+42		-
	T/G*		IVS4-53		-
	T/G*		IVS4-64		-

*Not previously reported change; nc: non-conservative change; scc: synonymous codon change; c: conservative change

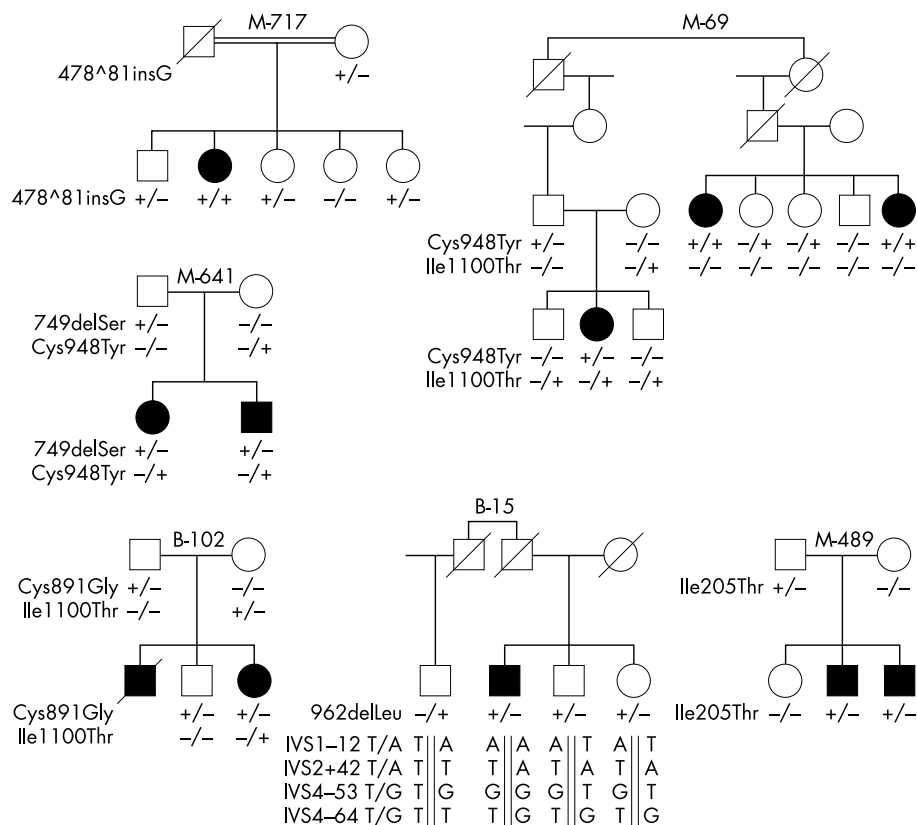

Figure 1 Pedigrees of the Spanish ARRPs families in which *CRB1* mutations have been identified.

non-consanguineous pedigrees, whereas cosegregation with the disease phenotype could be excluded in the five consanguineous families. In the control group (190 chromosomes), we found five alleles with Ser241Phe. A new silent variation (Lys205Lys) was identified in a carrier state in the two affected brothers of an ARRPs family. A patient showing a punctata albescens phenotype was a carrier of an A>G transition in intron 6 (IVS6+5 A>G). Segregation analysis in the patient's family showed no cosegregation with the disease phenotype. This change was not observed in 190 control chromosomes.

Cellular retinol binding protein 1 (*CRBP1*)

The mutational screening of the four exons and their flanking regions of the *CRBP1* gene in 92 unrelated patients allowed the identification of two single base pair substitutions in the amplicon containing exon 1 (table 2). These single nucleotide changes were C>T transitions in the 5' UTR region (position -37 and position -134) and correspond to two new polymorphisms with a minor allele frequency of 6% and 10%, respectively.

Crumbs homologue 1 (*CRB1*)

A total of 19 germline sequence variants were observed in this study, including seven pathogenic mutations, eight rare sequence variants, and four intronic polymorphisms (table 3). Seven mutations meet the criteria of pathogenicity, namely, absence in controls and segregation with the disease within the family. Six out of seven are novel: the non-conservative change (Ile>Thr) located in two different *CRB1* codons (205 and 1100, respectively); two in frame deletions causing the loss of serine (cd 749) and leucine (cd 962) residues; an amino acid changing variant Cys891Gly and one out of frame deletion caused by the insertion of a guanine between codons 160-161 creating a stop codon in position 168. We also observed the previously reported Cys948Tyr mutation. Fig 1

shows the pedigrees of the ARRPs families in which these mutations were identified.

In addition to deleterious mutations, we detected eight rare sequence variants that include three synonymous codon changes (Leu470Leu, Asn549Asn, and Asn1057Asn), two conservative amino acid changes (Arg769His and Arg1331His), two non-conservative amino acid changes (Thr289Met and Gln679Glu), and a G to A substitution at position -268 of the 5' UTR region (table 3). Family studies in all these eight substitutions excluded cosegregation with the disease phenotype. We identified four intronic variants (IVS1-12 T/A, IVS2+42 T/A, IVS4-53 T/G, and IVS4-64 T/G), all of them with a >1% frequency in the general population, which were regarded as polymorphisms.

DISCUSSION

RGR is a seven transmembrane domain receptor, a close relative of rhodopsin, found in the support cells for the photoreceptors, the RPE, and the Müller glia. Unlike rhodopsin, the RGR protein is coupled to all-*trans*-retinal that is isomerised to 11-*cis*-retinal upon light exposure.²³ The essential role of RGR in the process of vision was reinforced when (1) RP associated mutations in the *RGR* gene were described by Morimura *et al*²² and (2) the phenotype of mice with targeted disruption of *Rgr* was described.²⁴ Two mutations, a number of other changes less likely to be pathogenic, and four frequent polymorphisms were found in the mutational screening of the *RGR* gene performed by Morimura *et al*,²² which included a large group of patients with photoreceptor degeneration. In our group of Spanish ARRPs patients, we found three of the previously described polymorphisms with similar allelic frequencies, two variations (IVS6+5 A>G and Lys205Lys) and the Ser241Phe substitution (table 2). Morimura *et al*²² found the latter change heterozygously in two cases of recessive RP, two simplex cases, and one of 95 unrelated normal controls; one simplex case was

Table 4 Mutations described in the *CRB1* gene

Mutation type	Location	Nucleotide change	Effect	Reference
Missense				
1	cd 144	TTC > GTC	Phe144Val	26
2	cd 161	GCC > GTC	Ala161Val	20
3	cd 205	ATA > ACA	Ile205Thr	This report
4	cd 250	TGT > TGG	Cys250Trp	20
5	cd 383	TGT > TAT	Cys383Tyr	26
6	cd 433	TAT > TGT	Tyr433Cys	21
7	cd 480	TGT > CGT	Cys480Arg	26
8	cd 480	TGT > GGT	Cys480Gly	26
9	cd 681	TGT > TAT	Cys681Tyr	26
10	cd 745	ACG > ATG	Thr745Met	20
11	cd 764	CGT > TGT	Arg764Cys	20, 21, 26
12	cd 837	GAC > CAC	Asn837His	21
13	cd 891	TGC > GGC	Cys891Gly	This report
14	cd 894	AAC > AGC	Asn894Ser	21
15	cd 948	TGT > TAT	Cys948Tyr	20, 21, 26, this report
16	cd 1041	ATG > ACG	Met1041Thr	20
17	cd 1071	CTC > CCC	Leu1071Pro	20
18	cd 1100	ATA > AGA	Ile1100Arg	21
19	cd 1100	ATA > ACA	Ile1100Thr	This report
20	cd 1181	TGC > CGC	Cys1181Arg	21
21	cd 1205	GGA > AGA	Gly1205Arg	26
22	cd 1317	AAC > CAC	Asn1317His	26
23	cd 1321	-	Cys1321Ser	25
24	cd 1354	GCC > ACC	Ala1354Thr	21
Nonsense				
1	cd 403	TCA > TGA	Ser403Stop	20, 21
2	cd 801	AAG > TAG	Lys801Stop	21
3	cd 995	GAG > TAG	Glu995Stop	20
4	cd 1111	GAA > TAA	Glu1111Stop	21
5	cd 1332	TGC > TGA	Cys1332Stop	26
6	cd 1333	GAG > TAG	Glu1333Stop	21
Frameshift				
1	cd 37	del T	-	26
2	cd 86-87	ins GT	-	26
3	cd 143-144	del GATTC	-	26
4	cd 160-161	ins G	168 Stop	This report
5	cd 204-207	del AAATAGG	-	21, 26
6	cd 749	del 3bp	del Ser	This report
7	cd 729	ins Alu	-	20
8	cd 812-813	ins polyA	-	26
9	cd 850-851	del GGCT	-	26
10	cd 871	ins T	-	26
11	cd 962	del 3bp	del Leu	This report
12	cd 1115	del GGTTTCATTA	-	25
Splice site				
1	nt 2978+5	G>A	-	20, 21
2	nt 4013+1	G>T	-	21

homozygous Ser241Phe. We found the same substitution in nine unrelated ARRP patients (eight carriers and one homozygote). The pathogenic significance of this variant is difficult to assess because although there is a higher frequency of this variant in ARRP patients (10/182 alleles) compared with the frequency in control population (5/190 alleles) ($p=0.0005$), no cosegregation exists between the variant Ser241Phe and the disease in the Spanish consanguineous families.

CRBP1 is the carrier protein involved in the intracellular transport of retinol. Analysis of the visual cycle in *CRBP1* knockout mice suggests that the binding protein participates in a process that drives diffusion of all-transretinol from photoreceptor cells to RPE, perhaps delivering vitamin A to lecithin-retinol acyltransferase for esterification. This alleged involvement of the *CRBP1* gene in the visual process and the lack of mutational studies of this gene in patients affected by retinal degenerations prompted us to screen ARRP patients for pathological mutations in the four exons and flanking sequences of the *CRBP1* gene. We detected no disease causing mutation in our set of families but two new single nucleotide polymorphisms were found both in the 5' UTR region of the

gene (table 2). These polymorphisms were observed in controls as well as in unaffected family members.

The recent work of two groups of investigators^{20 21 25 26} has identified a number of mutations in the *CRB1* gene in patients affected by (1) a form of autosomal recessive RP (RP12), characterised by a preserved para-arteriolar retinal pigment epithelium (PPRPE) and by a severe loss of vision at age <20 years, (2) Leber congenital amaurosis, (3) RP with Coats-like exudative vasculopathy, and (4) a severe form of RP with common features. Table 4 summarises the reported mutations in the *CRB1* gene.

Bearing in mind these findings, we undertook the study of the *CRB1* gene in our set of ARRP families. Overall, seven pathogenic mutations were detected, six of which are reported for the first time. In addition, a number of rare sequence variants and intronic polymorphisms were identified.

The insertion of a G residue between nucleotides 478-481 was found in a homozygous state in the affected patient of a consanguineous family (M-717 in fig 1). This sequence alteration generates a stop signal in codon 168. All the remaining asymptomatic members of this family were heterozygous carriers of this mutation or homozygous for the wild type allele.

Table 5 Clinical findings in patients with mutations in the *CRB1* gene

Family	Mutations in <i>CRB1</i> gene	Age	Age of onset	Visual field	Visual acuity	Refraction	Fundus	ERG	Other symptoms
M-717	478 [*] 81insG	52 y	15 y	<5°	Light perception		Pale papilla Constricted arterioles Salt and pepper pigmentation in mid periphery and in posterior pole, more abundant around the macula Difficult to evaluate owing to opacities	Extinguished	Hyperopia Nystagmus
M-69	Cys948Tyr Cys948Tyr	55 y	1 y	Absolute scotoma	Amaurosis				Nystagmus Dense cataracts Microphthalmus Corneal leukoma secondary to keratoconus
M-69	Cys948Tyr Cys948Tyr	48 y	1 y	Absolute scotoma	Amaurosis		Difficult to evaluate owing to opacities		Nystagmus Dense cataracts Microphthalmus Corneal leukoma secondary to keratoconus
M-69	Cys948Tyr Ile1100Thr	21 y	3 y	<5°	0.1 RE 0.2 LE	+2+1.5 100° RE +1.5+1 80° LE	Bone spicule pigmentation Pale papilla Constricted arterioles	Extinguished	Nystagmus at 7 mth
M-641	Cys948Tyr 749delSer	11 y	4 mth	Central scotomae	0.3 RE 0.1 LE	+7.00-2.5 30° RE +7.00-1.00 150° LE	Bone spicule pigmentation in periphery Pale papilla Constricted arterioles	Extinguished	Strabismus
M-641	Cys948Tyr 749delSer	8 y	6 mth	Annular scotoma Peripheral sensitivity	0.1 RE 0.2 LE	+2.5+2 93° RE +2+2 98° LE	Bone spicule pigmentation in periphery Pale papilla Constricted arterioles PPRPE in temporal periphery	Extinguished	Congenital nystagmus
B-102	Cys891Gly Ile1100Thr	15 y	4 y		0.3 RE 0.2 LE		Bone spicule pigmentation Normal macula Pale papilla Vascular constriction	Extinguished	Hyperopia
B-15	962delLeu	54 y	13 y	RE: absolute scotoma LE: <5°	0.3 RE 0.2 LE	-0.25-0.25 170° RE -0.25-1.25 101° LE	Focal pigmentation in posterior pole Normal papilla Diffuse chorioretinal atrophy	Extinguished	Cataracts
M-489	Ile205Thr	37 y	At birth	Absolute scotoma	Light perception		Bone spicule pigmentation Pale papilla Narrow vessels	Extinguished	Nystagmus Keratoconus Franceschetti sign
M-489	Ile205Thr	35 y	At birth	Absolute scotoma	Light perception		Bone spicule pigmentation Pale papilla Narrow vessels	Extinguished	Nystagmus Franceschetti sign

Clinical findings of the affected patient (table 5) show an RP pattern with an early onset and a severe loss of vision under the age of 20. Given that the PPRPE phenotype can only be identified in the early/middle stages of the disease, the present fundus examination of this patient with advanced RP does not allow us to exclude a previous typical RP12 pattern.

A homozygous point mutation (G>A nucleotide 2843) causing the substitution Cys948Tyr was found in two RP sisters of family M-69 (fig 1). The clinical findings in these patients were consistent with a diagnosis of LCA (table 5). This substitution was also present in another branch of this family where the affected RP subject carried a non-conservative change Ile1100Thr in addition to Cys948Tyr. Clinical data of this patient (table 5) indicate an early onset of typical RP with macular symptoms. An extensive search for PPRPE signs yielded a negative result. The Cys948Tyr mutation was also identified in the two patients from family M-641 (fig 1), who also had a deletion of a serine residue in position 749. Ophthalmological examination of both affected sibs showed an RP12 phenotype with PPRPE, night blindness, and loss of visual field before the age of 10 years. Nystagmus and hyperopia were also observed as described in cases with an RP12 phenotype. Since the cysteine residue in position 948 is involved in the formation of disulphide bridges in the 14th EGF-like domain of *CRB1*, the correct folding of this domain may be impaired by changes affecting this position. The mutation Cys948Tyr, which is the *CRB1* mutation that is most frequently found, has been described in patients with Leber congenital amaurosis (LCA), with RP characterised by a preserved para-arteriolar retinal pigment epithelium, and in patients who had RP with Coats-like exudative vasculopathy. The three homozygous Cys948Tyr patients described to date were diagnosed with LCA. This clinical phenotype has also been associated with the presence of Cys948Tyr in combination with a frameshift mutation, with a missense mutation, and in patients in whom only the mutated allele Cys948Tyr has been found.^{20 21 26} The identification, in the present work, of two LCA patients (M-69 family) who are homozygous Cys948Tyr reinforces the view that Cys948Tyr is a mutation that leads to a severe phenotype when present homozygously, resulting in the complete loss of function of *CRB1*.²¹

The inheritance of Cys948Tyr in combination with Ile1100Thr (family M-69) is associated with an early onset RP phenotype without PPRPE whereas the coinheritance of Cys948Tyr and 749delSer (family M-641) manifests as an RP12 with PPRPE. These cases may have residual *CRB1* function as postulated by den Hollander *et al*,²¹ who identified four PPRPE patients who carried Cys948Tyr in combination with other missense mutations.

A new point mutation causing the substitution of the cysteine residue in position 891 by a glycine was found in compound heterozygosity with a non-conservative change (Ile1100Thr) in the proband of family B-102. Ophthalmological examination of this patient (table 5) showed a typical RP with an early onset and a rapid progression of the disease. Cys891 is a conserved residue located in the 13th EGF-like domain of *CRB1* and its substitution, impairing the formation of disulphide bridges, probably causes domain misfolding with secondary deleterious effects on the global conformation of the protein. The mutation Ile1100Thr that cosegregates in this family affects the same isoleucine residue found by Hollander *et al*²¹ to be mutated (Ile1100Arg) in a LCA proband.

A deletion of three nucleotides leading to the 962 del Leu of the laminin 3 motif was found, in a heterozygous state, in the proband of family B-15. Sequence analysis of the entire *CRB1* ORF did not show any additional mutation. The disease in this patient may be the result of an additional missing mutant *CRB1* allele (a point mutation in the non-coding regions of the *CRB1* gene or a large genomic rearrangement that would not be detected with the methodology used). Clinical findings in

this patient (table 5) meet all the standard definitions of retinitis pigmentosa except for the fundus appearance. He had night blindness from an early age, with a progressive visual field loss and a non-recordable ERG. The most striking finding in the fundus of this patient is the extensive atrophy of the retinal pigment epithelium and choroid. Choroid atrophy is widespread leaving areas of bare sclera, although other areas are still spared. There is little dispersion in pigment scattered all across the fundus. The pigment does not tend to assume the spicular configuration of deposits in typical RP. The disc is not pale but the retinal arteries are thin. This choroideremia (CHM)-like fundus prompted us to analyse the segregation of three intragenic markers of the *REP-1* gene (two SNPs located in exons 5 and 9 and a VNTR in exon 14) in the members of family B-15. Linkage between these informative markers and the disease phenotype can be excluded (data not shown). Thus, the diagnosis of a CHM associated with *REP-1* abnormalities can be rejected.

A novel non-conservative missense mutation, Ile205Thr, was identified in the affected brothers of family M-489 (fig 1). The Ile205Thr mutation changes an apolar residue conserved through evolution by a polar amino acid, in the 5th epidermal growth factor (EGF)-like domain of the *CRB1* protein. The mutational analysis of the entire coding region and promoter sequences of the *CRB1* gene failed to detect any additional mutation. The ophthalmological investigations of these affected members in family M-489 showed an LCA pattern defined by congenital blindness, nystagmus, extinguished ERG, and the presence of Franceschetti sign in both patients (table 5).

Six out of the seven rare sequence variants identified in this study have been previously reported in Leber congenital amaurosis patients.²⁶ Arg769His and Arg1331His were identified by Lotery *et al*²⁶ in control chromosomes and we were able to exclude cosegregation with the disease phenotype in our families. The lack of cosegregation has also been shown in the three synonymous codon changes (Leu470Leu, Asn549Asn, and Asn1057Asn) previously reported in LCA probands, indicating that these substitutions are not pathogenic. Two non-conservative amino acid changes (Thr289Met and Gln679Glu) were identified in Spanish ARRP patients. Thr289Met was initially considered to be related to LCA by Lotery *et al*,²⁶ who found this change in an affected proband. Nevertheless, we regard this change as non-pathogenic in line with the family studies that indicate a lack of cosegregation in the Spanish ARRP family (data not shown). A similar conclusion can be drawn for Gln679Glu, a previously unreported sequence variant identified in the present study.

Four intronic single nucleotide polymorphisms were found among the study participants. The most common change, located 12 bp upstream from the start of exon 2, has been previously reported to be identically distributed among the alleles of LCA probands and controls.²⁶ Similar results were obtained in our Spanish population. Analysis of the three new variants indicates that they represent polymorphisms in the human population, suggesting no particular relationship to retinal degeneration.

In conclusion, the data reported here provide (1) strong evidence against a direct involvement of the *RGR* and *CRBP1* genes in our set of Spanish autosomal recessive retinitis pigmentosa families and (2) data to establish the implication of the *CRB1* gene in the development of different types of retinal degeneration. The wide range of phenotypes associated with *CRB1* mutations underlines how the relationship between pathogenic mutations and disease phenotype is becoming increasingly complex. Further molecular and biochemical studies to elucidate the function of this protein will help us to define the events that result in blindness and will provide insights into the physiology of vision.

ACKNOWLEDGEMENTS

This work was supported by Fondo de Investigación Sanitaria (PI020052), Fundaluce (Fundación de lucha contra la ceguera), and ONCE (Organización Nacional de Ciegos de España). The authors belong to the "Grupo Multicéntrico Español para el Estudio de RP".

.....

Authors' affiliations

S Bernal, M Calaf, M Baiget, Servei de Genètica, Hospital de la Santa Creu i Sant Pau, Barcelona, Spain

M Garcia-Hoyos, C Ayuso, Servicio de Genética, Fundación Jiménez Díaz, Madrid, Spain

B Garcia-Sandoval, Servicio de Oftalmología, Fundación Jiménez Díaz, Madrid, Spain

J Rosell, Servei de Genètica, Hospital Son Dureta, Palma de Mallorca

A Adan, Servei d'Oftalmologia, Hospital de la Santa Creu i Sant Pau, Barcelona, Spain

Correspondence to: Dr M Baiget, Servei de Genètica, Hospital de la Santa Creu i Sant Pau, Pare Claret 167, 08025 Barcelona, Spain; mbaiget@hsp.santpau.es

REFERENCES

- Ayuso C**, Garcia-Sandoval B, Najera C, Valverde D, Carballo M, Antiñolo G. Retinitis pigmentosa in Spain. *Clin Genet* 1995;**48**:120-2.
- Bayes M**, Valverde D, Balcells S, Grinberg D, Vilageliu L, Benitez J, Ayuso C, Beneyto M, Baiget M, Gonzalez-Duarte R. Evidence against involvement of recoverin in autosomal recessive retinitis pigmentosa in 42 Spanish families. *Hum Genet* 1995;**96**:89-94.
- Bayes M**, Martinez-Mir A, Valverde D, del Rio E, Vilageliu L, Grinberg D, Balcells S, Ayuso C, Baiget M, Gonzalez-Duarte R. Autosomal recessive retinitis pigmentosa in Spain: evaluation of four genes and two loci involved in the disease. *Clin Genet* 1996;**50**:380-7.
- Bayés M**. *Anàlisi genètica i molecular per a la identificació de loci responsables de la RP autosòmica recessiva*. Doctoral thesis, University of Barcelona, 1996.
- Valverde D**, Vazquez-Gundin F, del Rio E, Calaf M, Fernandez JL, Baiget M. Analysis of the IRBP gene as a cause of RP in 45 ARRP Spanish families. *Ophthalmic Genet* 1998;**19**:197-202.
- Martinez-Mir A**. *Estudi de les bases moleculars de la RP autosòmica recessiva*. Doctoral thesis, University of Barcelona, 1998.
- Bernal S**, Calaf M, Adan A, Solana T, Valverde D, Ayuso C, Baiget M. Evaluation of RBP1 in 50 autosomal recessive retinitis pigmentosa and 4 retinitis punctata albescens Spanish families. *Ophthalmic Genet* 2001;**22**:19-25.
- Bayes M**, Giordano M, Balcells S, Grinberg D, Vilageliu L, Martinez I, Ayuso C, Benitez J, Ramos-Arroyo MA, Chivelet P, Solans T, Valverde D, Anselm S, Goossens M, Baiget M, Gonzalez R, Besmond C. Homozygous tandem duplication within the gene encoding the beta subunit of rod phosphodiesterase as a cause for autosomal recessive retinitis pigmentosa. *Hum Mutat* 1995;**5**:228-34.
- Valverde D**, Baiget M, Seminago R, del Rio E, Garcia B, del Rio T, Bayes M, Balcells S, Martinez A, Grinberg D, Ayuso C. Identification of a novel R552Q mutation in exon 13 of the beta-subunit of rod phosphodiesterase gene in a Spanish family with autosomal recessive retinitis pigmentosa. *Hum Mutat* 1996;**8**:393-4.
- Valverde D**, Solans T, Grinberg D, Balcells S, Vilageliu L, Bayes M, Chivelet P, Besmond C, Goossens M, Gonzalez-Duarte R, Baiget M. A novel mutation in exon 17 of the β subunit of rod phosphodiesterase in two RP sisters of a consanguineous family. *Hum Genet* 1996;**97**:35-8.
- Baiget M**, Calaf M, Valverde D, Del Rio E, Reig C, Carballo M, Calvo MT, González-Duarte R. Identificación de dos mutaciones alélicas en el gen de la subunidad beta de la fosfodiesterasa en una familia española afectada de retinitis pigmentaria autosómica recesiva. *Med Clin* 1998;**111**:420-2.
- Martinez-Mir A**, Paloma E, Allikmets R, Ayuso C, del Rio T, Dean M, Vilageliu L, Gonzalez-Duarte R, Balcells S. Retinitis pigmentosa caused by a homozygous mutation in the Stargardt disease gene ABCR. *Nat Genet* 1998;**18**:11-12.
- Paloma E**, Hjelmqvist L, Bayes M, Garcia-Sandoval B, Ayuso C, Balcells S, Gonzalez-Duarte R. Novel mutations in the TULP1 gene causing autosomal recessive retinitis pigmentosa. *Invest Ophthalmol Vis Sci* 2000;**41**:656-9.
- Paloma E**, Martínez-Mir A, García-Sandoval B, Ayuso C, Vilageliu L, González-Duarte R, Balcells S. Novel homozygous mutation in the alpha subunit of the rod cGMP gated channel (CNGA1) in two Spanish sibs affected with autosomal recessive retinitis pigmentosa. *J Med Genet* 2002;**39**:e66.
- Bernal S**, Ayuso C, Antiñolo G, Gimenez A, Borrego S, Trujillo MJ, Marcos I, Calaf M, Del Rio E, Baiget M. Mutations in USH2A in Spanish patients with autosomal recessive retinitis pigmentosa: high prevalence and phenotypic variation. *J Med Genet* 2003;**40**:e8.
- Jiang M**, Pandey S, Fong HKW. An opsin homologue in the retina and pigment epithelium. *Invest Ophthalmol Vis Sci* 1993;**34**:3669-78.
- Den Hollander AI**, Johnson K, de Kok YJM, Klebes A, Brunner HG, Knust E, Cremers FPM. CRB1 has a cytoplasmatic domain that is functionally conserved between human and Drosophila. *Hum Mol Genet* 2001;**10**:2767-73.
- Marmor MF**, Zrenner E. Standard for clinical electroretinography. *Int Soc Clin Electrophysiol Vision Doc Ophthalmol* 1998-99;**97**:143-56.
- Miller SA**, Dykes DD, Polesky H. A simple salting out procedure for extracting DNA from human nucleated cells. *Nucleic Acids Res* 1989;**16**:1215.
- Den Hollander AI**, ten Brink JB, de Kok YJM, van Soest S, van den Born LJ, van Driel MA, van de Pol DJR, Payne AM, Bhattacharya SS, Kellner U, Hoyng CB, Westerveld A, Brunner HG, Bleeker-Wagemakers EM, Deutman AF, Heckenlively JR, Cremers FPM, Bergen AAB. Mutations in a human homologue of Drosophila crumbs cause retinitis pigmentosa (RP12). *Nat Genet* 1999;**23**:217-21.
- Den Hollander AI**, Heckenlively JR, van den Born LJ, de Kok YJM, van der Velde-Visser SD, Kellner U, Jurklics B, van Schooneveld MJ, Blankenagel A, Rohrschneider K, Wissinger B, Cruysberg JRM, Deutman AF, Brunner HG, Apfelstedt-Sylla E, Hoyng CB, Cremers FPM. Leber congenital amaurosis and retinitis pigmentosa with Coats-like exudative vasculopathy are associated with mutations in the Crumbs homologue 1 (CRB1) gene. *Am J Hum Genet* 2001;**69**:198-203.
- Morimura H**, Saindelle-Ribeau deau F, Berson EL, Dryja TP. Mutations in RGR, encoding a light-sensitive opsin homologue, in patients with retinitis pigmentosa. *Nat Genet* 1999;**23**:393-4.
- Hao W**, Fong HKW. The endogenous chromophore of retinal G protein-coupled receptor opsin from the pigment epithelium. *J Biol Chem* 1999;**274**:6085-90.
- Chen P**, Hao W, Rife L, Wang XP, Shen D, Chen J, Ogden T, Van Boemel GB, Wu L, Yang M, Fong HKW. A photic visual cycle of rhodopsin regeneration is dependent on Rgr. *Nat Genet* 2001;**28**:256-60.
- Lotery AJ**, Malik A, Shami SA, Sindhi M, Chohan B, Maqbool C, Moore PA, Denton MJ, Stone EM. CRB1 mutations may result in retinitis pigmentosa without para-arteriolar RPE preservation. *Ophthalmic Genet* 2001;**22**:163-9.
- Lotery AJ**, Jacobson SG, Fishman GA, Weleber RG, Fulton AB, Namperumalsamy P, Hoen E, Levin AV, Grover S, Rosenow JR, Kopp KK, Sheffield VC, Stone EM. Mutations in the CRB1 gene cause Leber congenital amaurosis. *Arch Ophthalmol* 2001;**119**:415-20.